

REMER

RUBINETTERIE

SERIE
SERIES

CLASS LINE

CODICE
CODE

L02

IMMAGINE - IMAGE



DESCRIZIONE - DESCRIPTION

Miscelatore vasca con deviatore integrato con flessibile 150 cm e doccetta a 4 funzioni con getti anticalcare e supporto snodato.

Wall mounted bath mixer with integrated diverter, flexible hose cm 150 and 4 functions antilimestone handshower and swivel shower holder.

SCHEDA TECNICA - TECHNICAL FEATURES

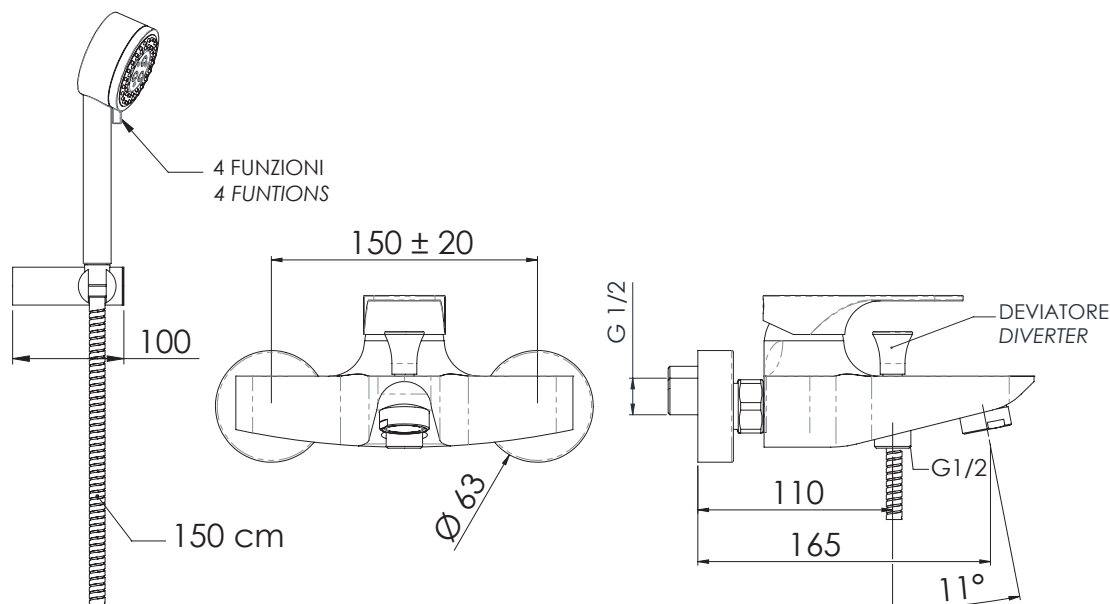

CARATTERISTICHE - FEATURES



2 Vie
2 Ways



Getto intenso a risparmio idrico
Intense water-saving jet



Getto spray ampia copertura e getto intenso esterno a risparmio idrico
Wide coverage spray jet and intense water saving external jet



Con Getti Anticalcare
With Antilimestone Jets



Getto Esterno
External Jet



Getto aerato intenso
Intense aerated jet



Flessibile Lungo 150 cm
Flexible Length 150 cm

COMPONENTI - COMPONENTS



Cartuccia R50
Cartridge R50



Aeratore 84A
Aerator 84A

FINITURE - FINISHING



CR
Cromo
Chrome

REMER Rubinetterie S.p.A.

Via Leonardo Da Vinci, 83 - 20062 Cassano d'Adda (MI) - Italy - Tel. +39 0363 364211 - info@remer.eu - www.remer.eu